



Assembly Instruction

6500 MXBM

Assembly Instruction:

- 1- Secure the Mobile Base (Item 3) using the four M8 Washers (Item 5) and the four M8 Hex Socket Cap Screw (Item 4).
- 2- Install the Casters (Item 1) underneath the Mobile Base (Item 3).
- 3- The Cover Plates (Item 2) can be removed to give access to the Castor brake (Item 1).

PART LIST

ITEM	QTY	PART NUMBER	DESCRIPTION
1	4	STK-Q-05035	M4.8 x 10mm Truss Head Tapping Screw
2	4	STK-Q-00651	M12 x 20mm Hex Socket Cap Screw
3	4	STK-Q-10655	M12 Flat Washer
4	4	886CB200	M12 Caster Wheel with Brake
5	1	6500 MXBMxyy-B	6500 MXBM - Mobile base
6	4	6500 MXBN-C	6500 MXBM - Cover plate

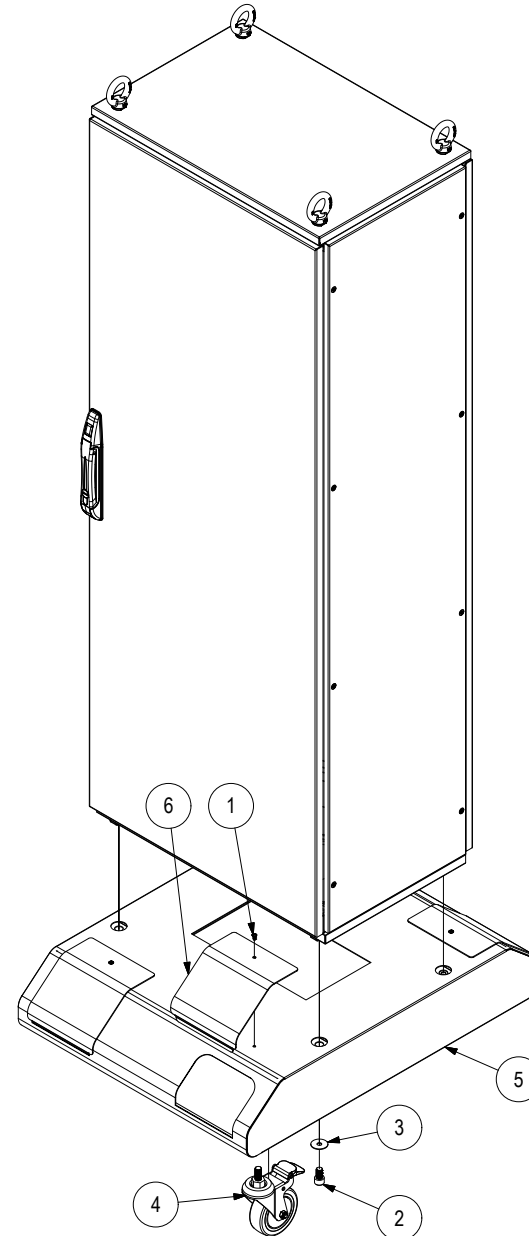



Instruction D'assemblage 6500 MXBM

Instruction pour l'assemblage:

- 1- Visser la Base Mobile (Item 3) en utilisant les quatre Rondelles M8 (Item 5) et les quatre Vis M8 (Item 4)
- 2- Installer les Roulettes (Item 1) sous la Base Mobile (Item 3).
- 3- Le frein des Roulettes (Item 1) peut-être activé en enlevant le Couvrele (Item 2).

LISTE DE MATÉRIELS			
ITEM	QTÉE	NO° PIÈCE	DESCRIPTION
1	4	STK-Q-05035	Vis à Métal M4.8 x 10mm
2	4	STK-Q-00651	Vis M12 x 20mm
3	4	STK-Q-10655	Ronelle M12
4	4	886CB200	Roulette avec Frein
5	1	6500 MXBMxxyy-B	6500 MXBM - Base Mobile
6	4	6500 MXBN-C	6500 MXBM - Couvrele

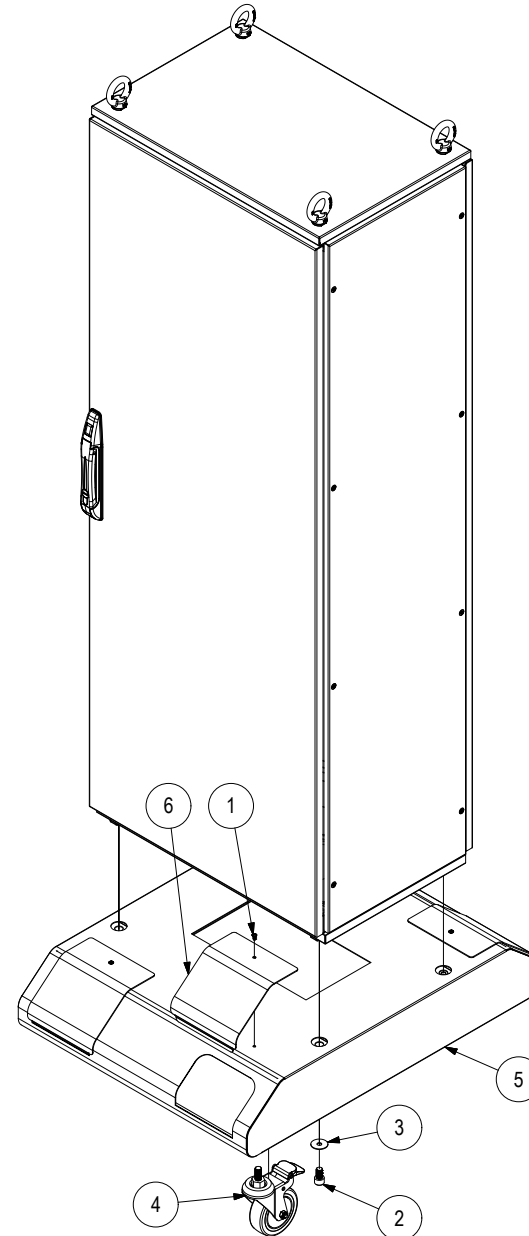

Instruction d'assemblage 6500 MXBT

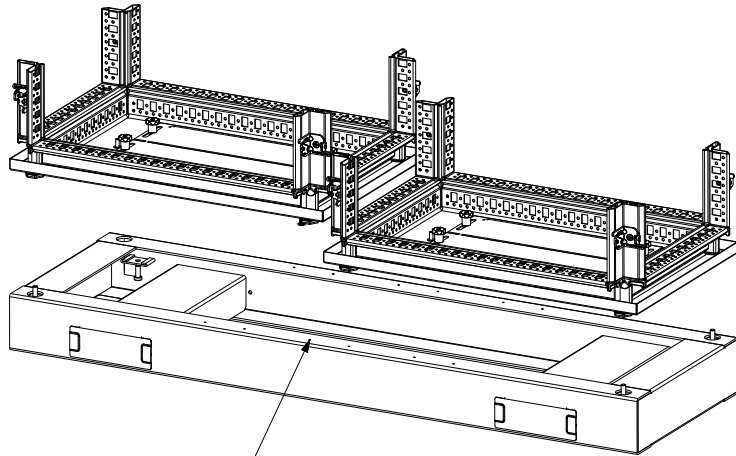

Utiliser les trous de Départ de la Base de transport pour percer les trous de $\varnothing 27\text{mm}$ nécessaire à la fixation des Cabinets.

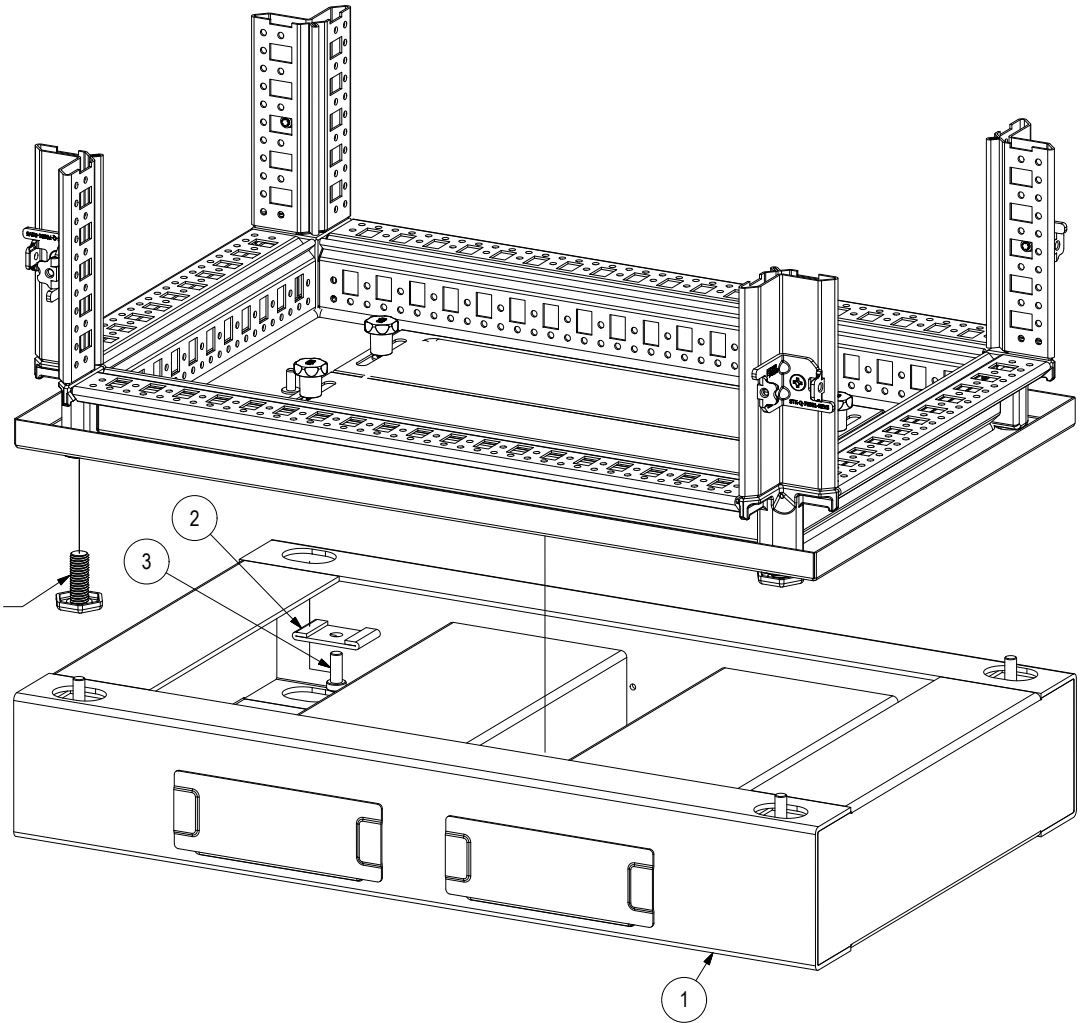

Enlevé les pieds ajustables

Instruction pour l'assemblage:

- 1- Enlever tous les *Pieds de Levage* qui sont déjà installés sous le Cabinet
- 2- Installer la *Base de Transport* (Item 1) sous le Cabinet et utiliser les *Vis M8 x 20mm* et les *Rondelles M8* (Item 3 et 2) pour la fixer au cabinet.

LISTE DE MATÉRIELS

ITEM	QTÉE	NO° PIÈCE	DESCRIPTION
1		6500MXBTXXYY	6500MXBT Base de Transport
2	4	6500MXBT-W	6500MXBT-W Rondelle M8
3	4	STK-Q-00750	Vis M8 x 20mm à tete cylindrique à six pans creux



Assembly Instruction

6500 MXBT

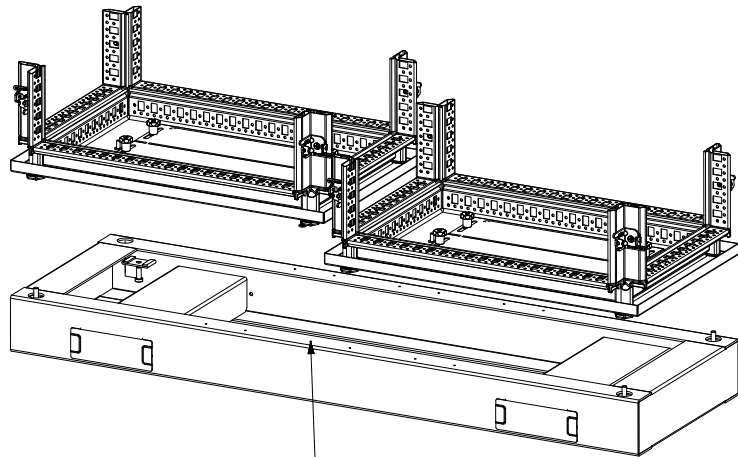

Use the Pilot Holes of the Transportation Base to Drill needed Holes of $\varnothing 27\text{mm}$ to Fix it on the Cabinets.

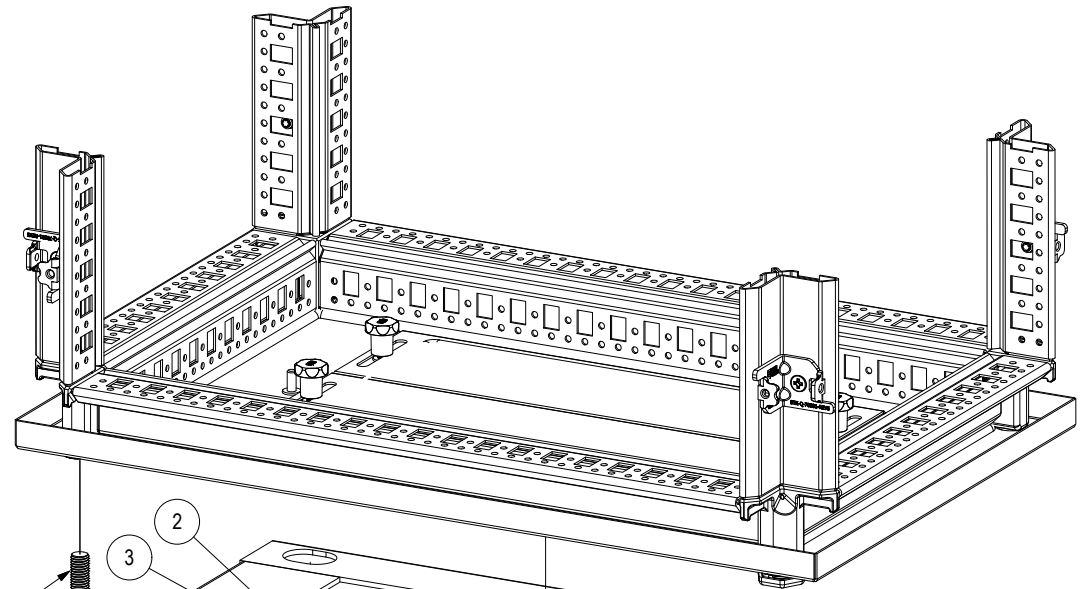

Remove all the leveler feet

Assembly Instruction:

- 1- Remove All the *Leveler Feet* Installed under the Cabinet .
- 2- Install the *Transportation Base* (Item 1) in position and use the *M8 x 20mm screws* and the *M8 Washers* (Item 3 and 2) to fix it.

PART LIST			
ITEM	QTY	PART NUMBER	DESCRIPTION
1	1	STK-Q-16080	M6 x 16mm Ground Stud
2	4	6500MXBT-W	6500MXBT-W Washer M8
3	4	STK-Q-00750	M8 x 20mm Hex Socket Cap Screw (DIN 6912)

Instruction d'assemblage 6500 MXPLW

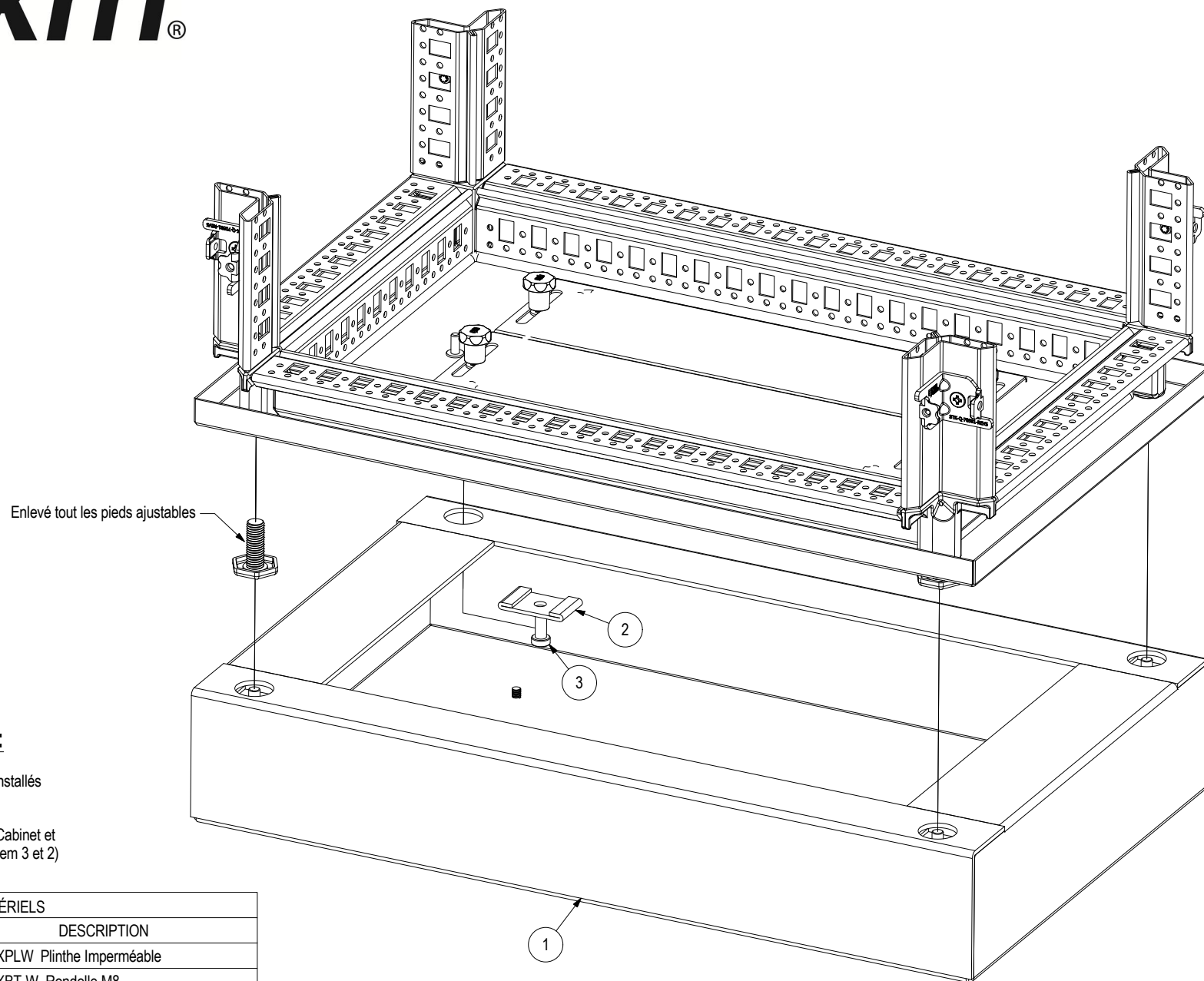

Instruction pour l'assemblage:

- 1- Enlever tous les *Pieds de Levage* qui sont déjà installés sous le Cabinet
- 2- Installer la *Plinthe Imperméable* (Item 1) sous le Cabinet et utiliser les *Vis M8 x 20mm* et les *Rondelles M8* (Item 3 et 2) pour la fixer au cabinet.

LISTE DE MATÉRIELS

ITEM	QTÉE	NO° PIÈCE	DESCRIPTION
1	1	6500MXPLW	6500MXPLW Plinthe Imperméable
2	4	6500MXBT-W	6500MXBT-W Rondelle M8
3	4	STK-Q-00750-NT	Vis M8 x 20mm à tete cylindrique à six pans creux



Assembly Instruction 6500 MXPLW

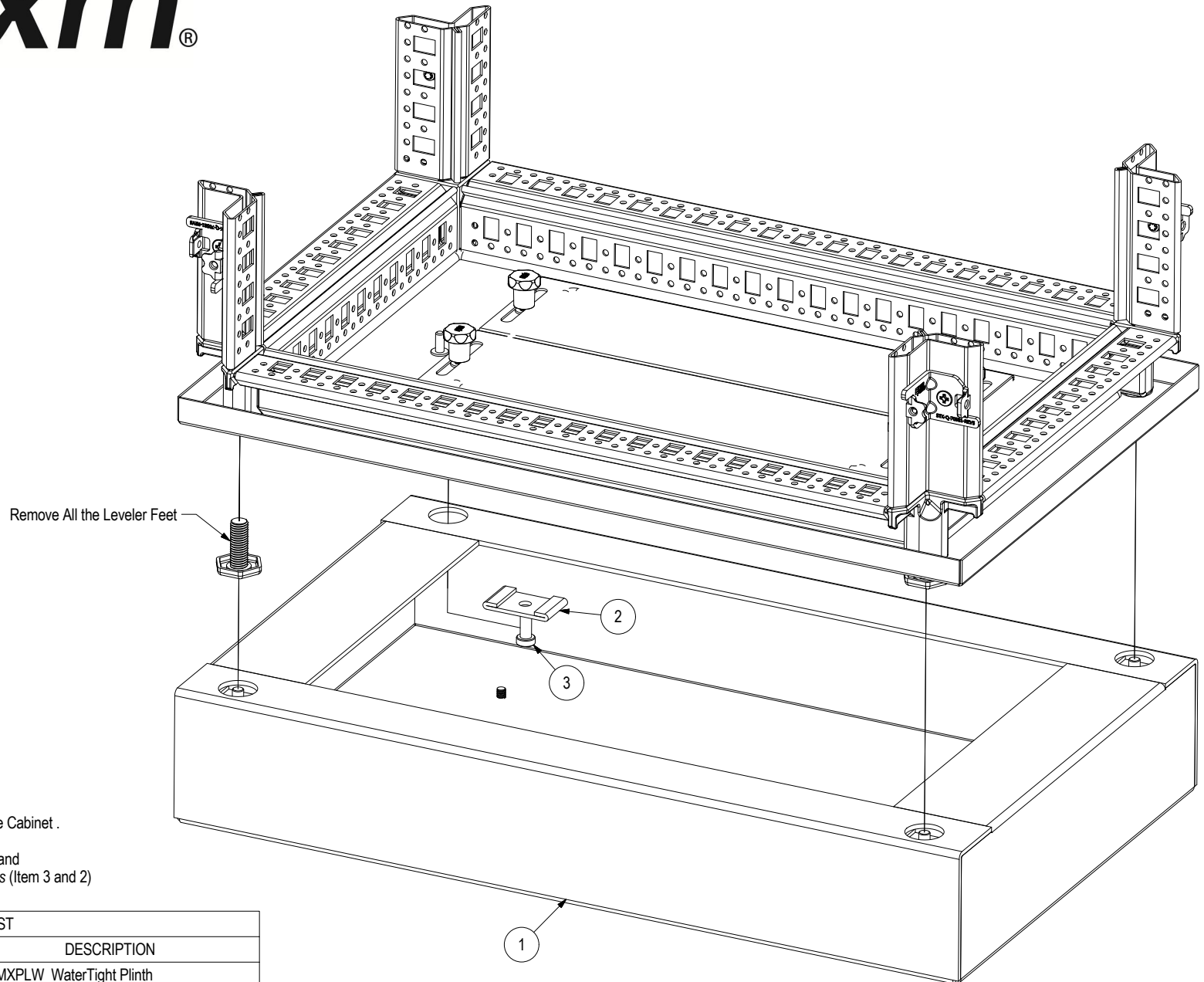

Assembly Instruction:

- 1- Remove All the *Leveler Feet* Installed under the Cabinet .
- 2- Install the *WaterTight Plinth* (Item 1) in position and use the *M8 x 20mm screws* and the *M8 Washers* (Item 3 and 2) to fix it.

PART LIST

ITEM	QTY	PART NUMBER	DESCRIPTION
1	1	6500MXPLW	6500MXPLW WaterTight Plinth
2	4	6500MXBT-W	6500MXBT-W Washer M8
3	4	STK-Q-00750	M8 x 20mm Hex Socket Cap Screw (DIN 6912)