



Assembly Instruction

6500 MXBA

Assembly Instruction:

- 1- Remove the M8 Nuts which retain the Cabinets together.
(6 Nuts when Standard Joining Bracket is used,
12 Nuts when Heavy duty Joining Bracket is used.)
- 2- Position the Barrier Panel (Item 2) on Joining Brackets.
- 3- Put the M8 Nuts in place.

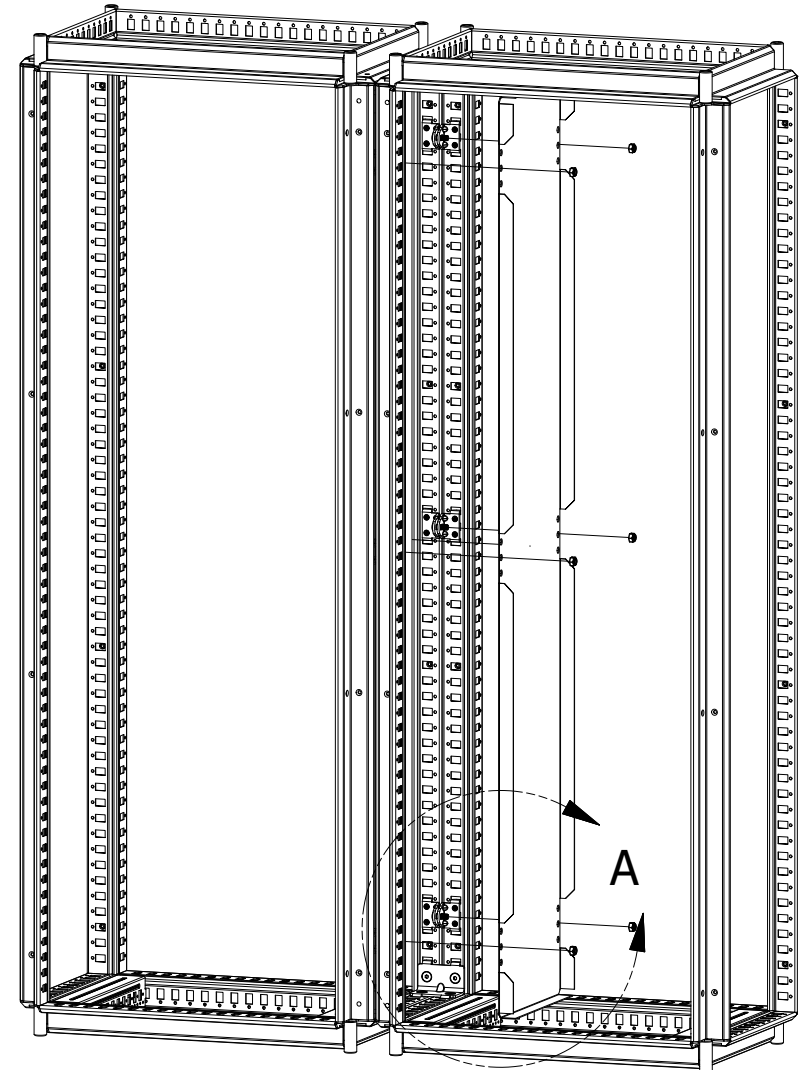
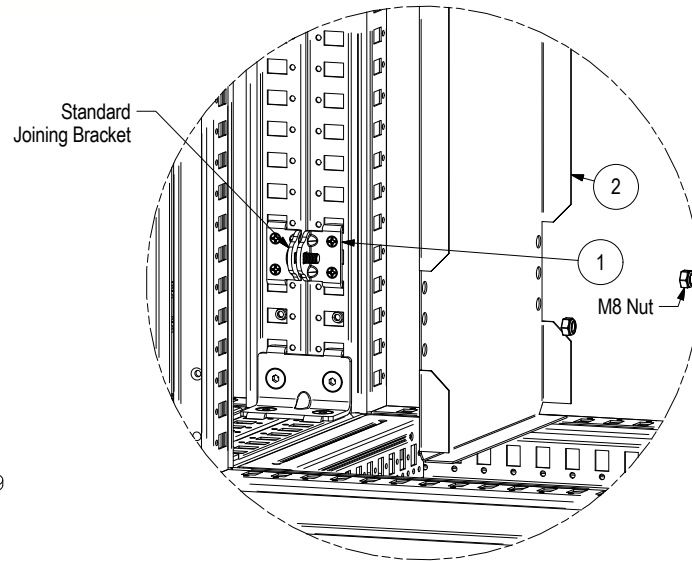

**Standard
Joining Bracket**

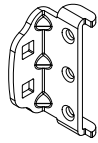

**Heavy duty
Joining Bracket**

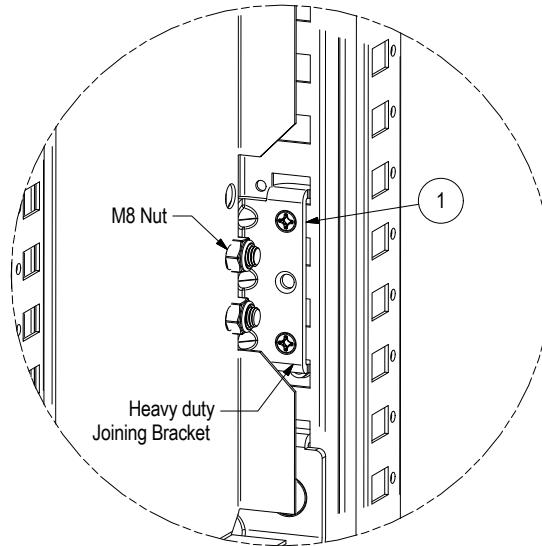

PART LIST

ITEM	PART NUMBER	DESCRIPTION
1	6500MXJO	6500 MXJO Standard Joining Kit
2	6500 MXBAxyy	6500 MXBA Barrier Panel



Instruction d'assemblage 6500 MXBP

Instruction pour l'assemblage:

- 1- Enlever les Écrous M8 qui retiennent les Cabinets ensemble.
(6 Écrous lorsque la Bracket d'Union Standard est utilisée.
12 Écrous lorsque la Bracket d'Union Renforcée est utilisée.)
- 2- Positionner le Panneau d'arrêt Perforé (Item 2) sur les Brackets d'Union.
- 3- Remettre les Écrous M8 à leur place.

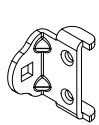
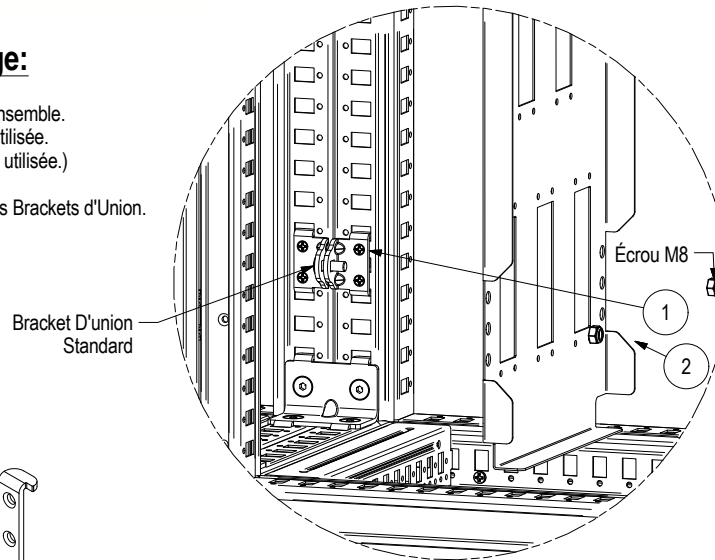

**Bracket d'Union
Standard**

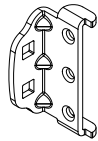

**Bracket d'Union
Renforcée**

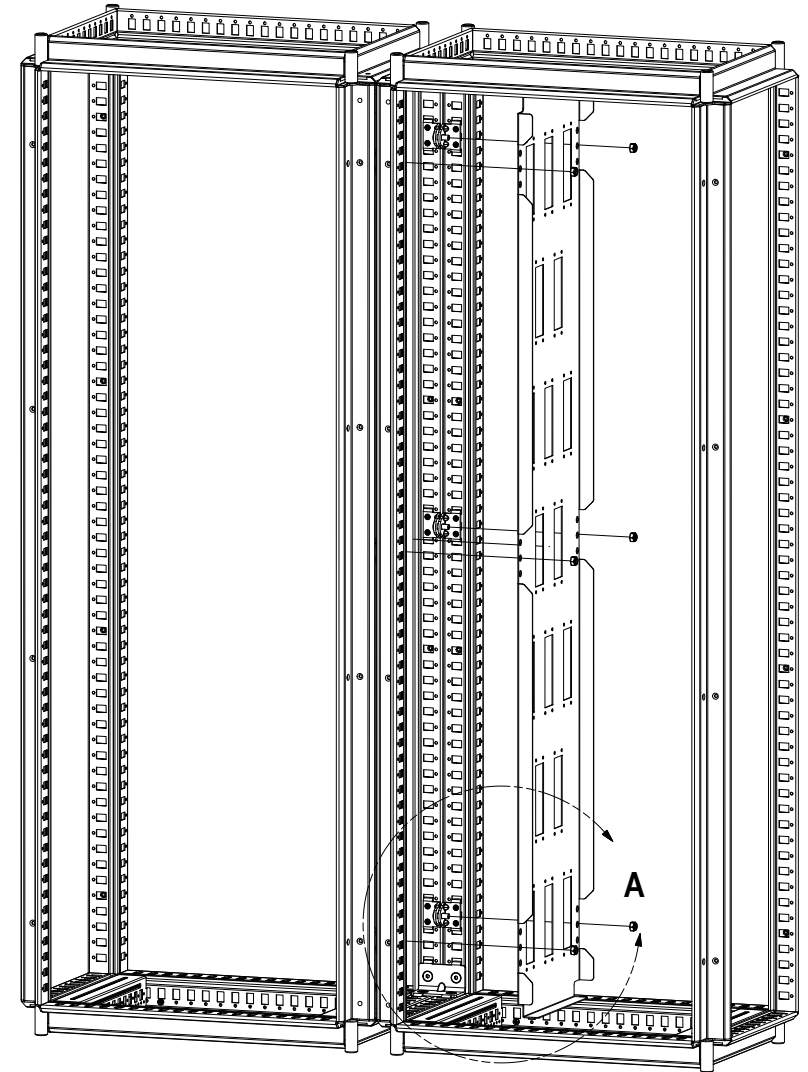
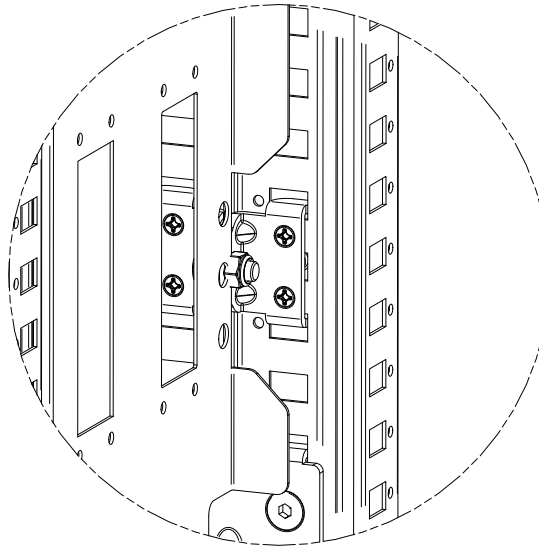

LISTE DE MATÉRIELS

ITEM	PART NUMBER	DESCRIPTION
1	6500MXJO	6500 MXJO Bracket d'Union
2	6500 MXBPxyy	6500 MXBP Panneau d'arrêt Perforé



Assembly Instruction

6500 MXBP

Assembly Instruction:

- 1- Remove the M8 Nuts which retain the Cabinets together.
(6 Nuts when Standard Joining Bracket is used,
12 Nuts when Heavy duty Joining Bracket is used.)
- 2- Position the Perforated Barrier Panel (Item 2) on Joining Brackets.
- 3- Put the M8 Nuts in place.

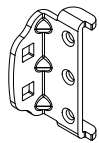
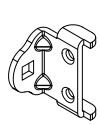
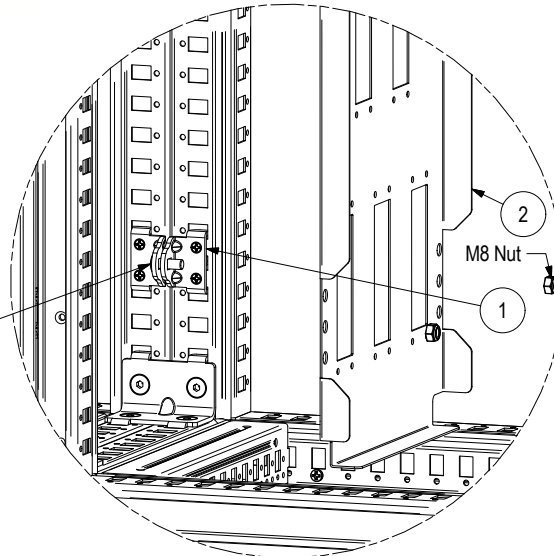

**Standard
Joining Bracket**

**Heavy duty
Joining Bracket**

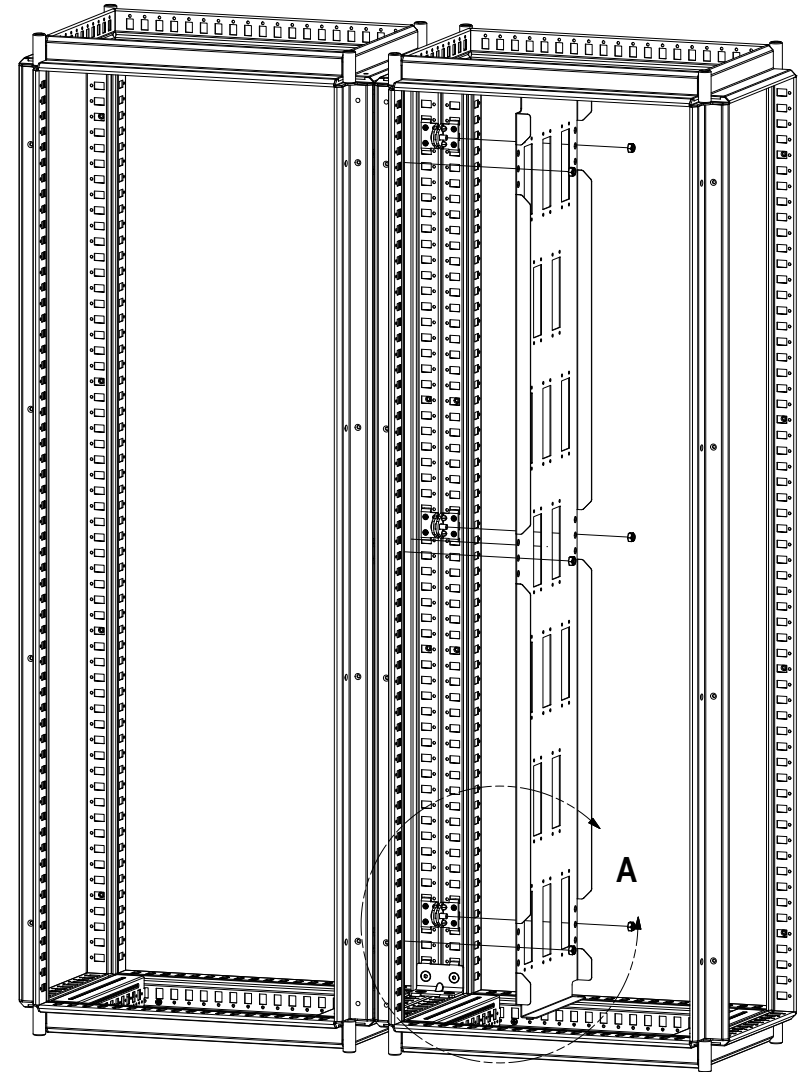
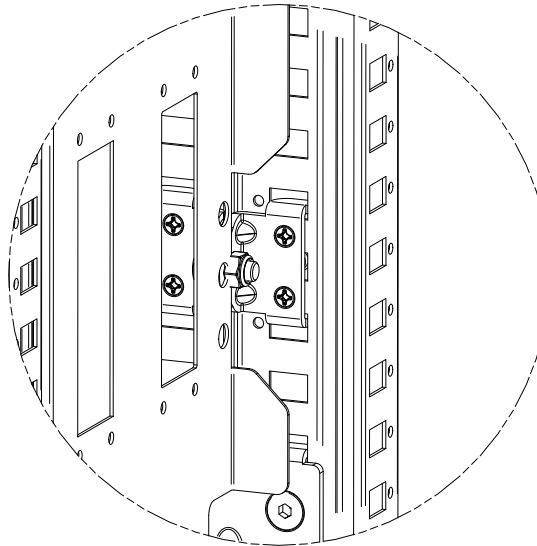

PART LIST

ITEM	PART NUMBER	DESCRIPTION
1	6500MXJO	6500 MXJO Standard Joining Kit
2	6500 MXBPxyy	6500 MXBP Perforated Barrier Panel



Instruction d'assemblage 6500 MXBA

Instruction pour l'assemblage:

- 1- Enlever les Écrous M8 qui retiennent les Cabinets ensemble.
(6 Écrous lorsque la Bracket d'Union Standard est utilisée.
12 Écrous lorsque la Bracket d'Union Renforcée est utilisée.)
- 2- Positionner le Panneau d'arrêt (Item 2) sur les Brackets d'Union.
- 3- Remettre les Écrous M8 à leur place.

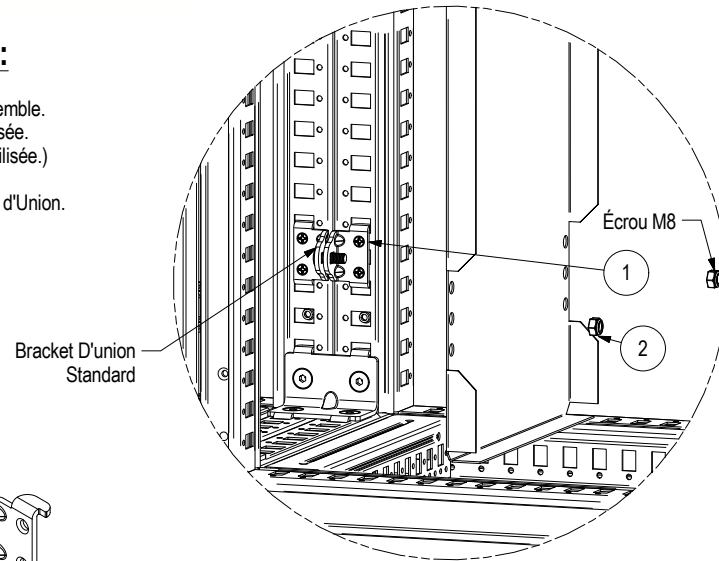

**Bracket d'Union
Standard**

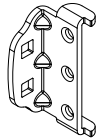

**Bracket d'Union
Renforcée**

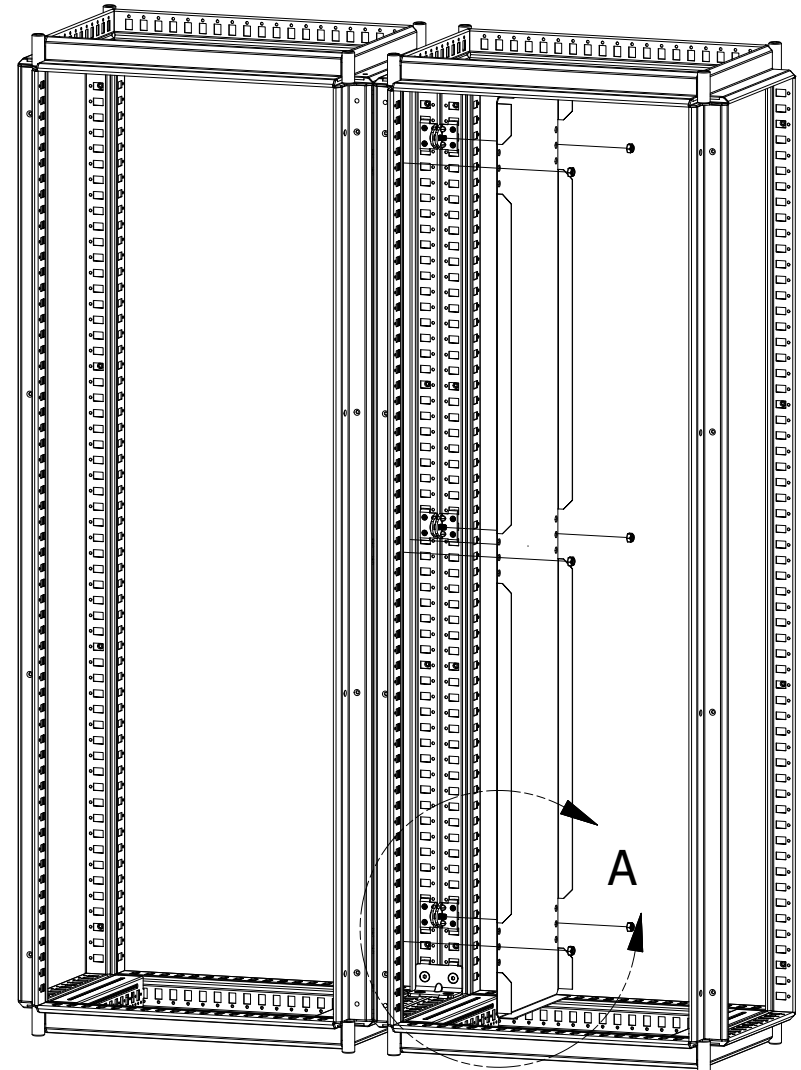
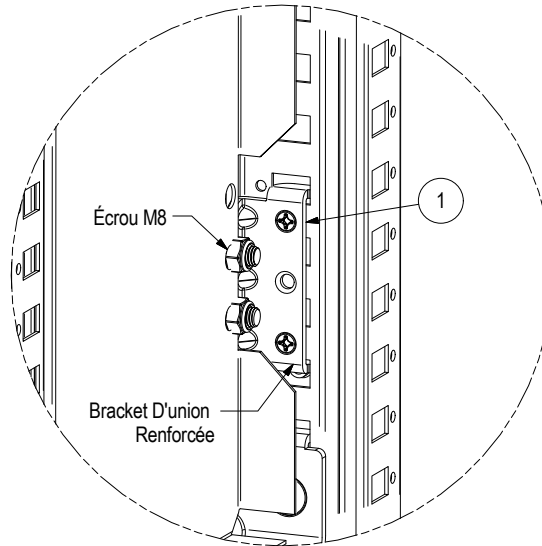

LISTE DE MATÉRIELS

ITEM	NO° PIÈCE	DESCRIPTION
1	6500MXJO	6500 MXJO Bracket d'Union
2	6500 MXBAxxyy	6500 MXBA Panneau d'arrêt